

ASCO[®] Series 7000
We Keep Your Power On[®]

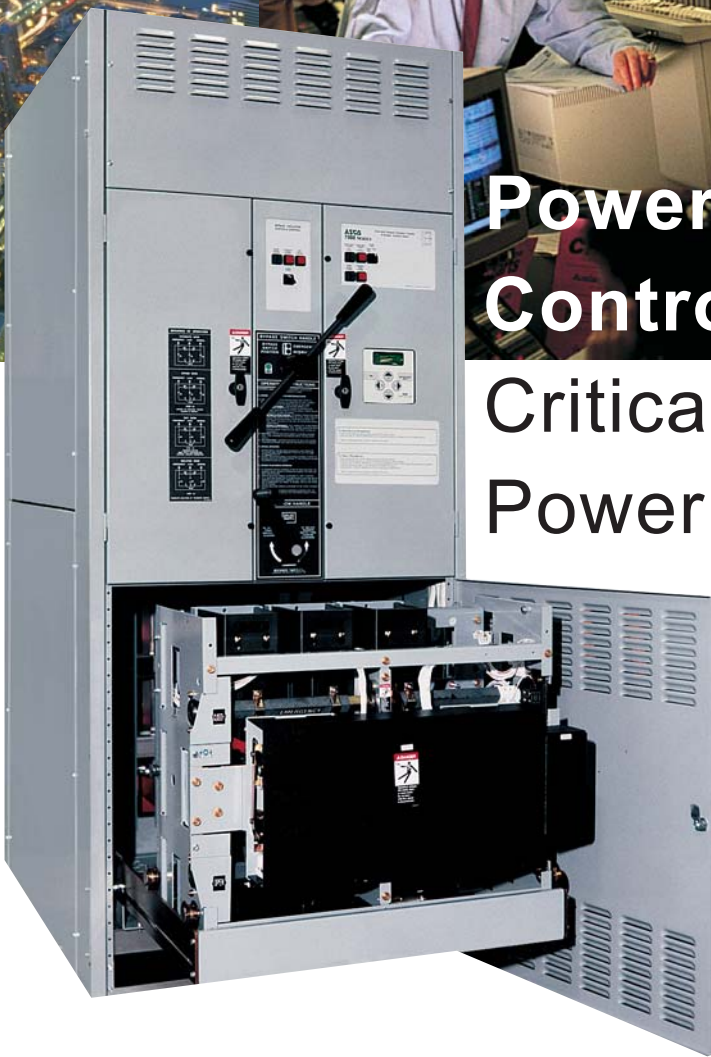

Power Switching and Control Solutions for Critical and Distributed Power Applications



ASCO[®] Series 7000



Critical Loads Demand ASCO

- **Healthcare Facilities**
- **Commercial Buildings / Industrial Buildings**
- **Web Hosting, Internet Data Centers**
- **Telecom Central Offices**
- **Process Manufacturing / Wafer Fabrication Plants /**
- **Distributed Power / Load Management**

As we become more dependent on the quality and reliability of electrical power, interruption or complete loss of power can create serious and even crippling financial losses, or impose dangers to life and safety.

ASCO Power Technologies (ASCO) provides the solutions to handle the transfer of critical loads to emergency sources reliably and with state of the art products. Using ASCO products can mean the difference between a minor inconvenience and a major catastrophe. You'll find ASCO Power Transfer Switches wherever there is a critical load to be protected.

When flexibility in power switching is a must, ASCO offers a variety of product solutions to meet virtually every application requirement, including distributed generation applications. That's why the 7000 Series is available in open, delayed, closed and closed soft load configurations. Additionally, switched or overlapping neutral options provide for reliable operation of ground fault protection systems and reduction of voltage transients from unbalanced load switching.

ASCO Power Transfer Switches are the first CE Marked, IEC 60947-6-1 compliant Transfer Switches in the world which have been certified by a notified body of the European Union.

ASCO® The Recognized Leader in Power Transfer Switch Technology Offers the Most Advanced Transfer Switches in the World.

7000 Series

ASCO Power Transfer Switches are the standard of the industry. High speed transfer of loads between alternate sources of power, regardless of ampacity size, is achieved by a reliable, field proven solenoid operating mechanism. When combined with a programmable microprocessor controller with keypad and LCD display, they offer the most advanced method of transferring all types of loads, such as motors, electronic drives, UPSs and microprocessor based systems. 7000 Series Power Transfer Switches are available open or enclosed, in ampacity sizes from 30 through 4000 amperes with the largest selection of optional accessories offered anywhere. All switching configurations are available with an integrally mounted bypass-isolation switch and/or rated for use in service entrance applications.



Fig. 1: Three Pole 7000 Series Automatic Transfer Switch rated 1600 amperes (shown with optional front connected terminals and Power Manager).

7000 Series Power Transfer Switches Product Features

- Conventional two-position transfer configuration, plus closed and delayed transition modes of operation. All configurations available with either automatic or non-automatic control.
- UL listed to 1008 Transfer Switch Equipment & CSA certified to CSA 22.2 No.178-1978 Automatic Transfer Switches.
- Independently qualified and certified to IEC 60947-6-1, CE marked (optional). (Limited to certain accessories.)
- Rated up to 600 VAC, 30 through 4000 amperes.
- Reliable and field proven solenoid operating mechanism.
- High withstand and close-on ratings including short time withstand current rating for optimum flexibility in circuit breaker coordination (600-4000 amperes).
- Solid, switched, or overlapping neutral conductor options.
- Front replaceable main and arcing contacts (600-4000 amperes).
- Programmable microprocessor controller with keypad and LCD display.
- Centrally located terminal block for customer control connections (260-4000 amperes).
- 16mm, industrial grade control switches and indicating lights.
- Switch position LED indicators and source acceptability lights.
- Standard ground conductor connections.
- Four auxiliary contacts, two contacts closed when switch is in normal position and two contacts closed when switch is in emergency position.
- Local/remote communications capability for interfacing with ASCO PowerQuest® or SiteWeb™ communication products.

ASCO® 7000 Series Power Switching Solutions



Fig. 2: Four pole, Closed-Transition Transfer Switch rated 1000 amperes in Type 1 enclosure.

Closed-Transition Transfer Switching

ASCO Automatic Closed-Transition Transfer Switches feature main contacts that overlap, permitting the transfer of electrical loads without power interruption. The switch transfers in a make-before-break mode if both sources are within acceptable parameters. Control logic continuously monitors source conditions and automatically determines whether the load transfer should be open (conventional non-overlap mode) or closed transition. Available 150 through 4000 amperes.

Closed-Transition Transfer within 5 electrical degrees is achieved passively, without control of engine generator set. Therefore, no additional control wire runs are required between the ATS and engine generator set governor. Plus, protective relaying may not be required under normal operation since the contact overlap time is less than 100 milliseconds (consult your local utility on protective relay requirements).

Failure to synchronize indication and extended parallel time protection is built-in to all 7000 Series closed transition controls to prevent abnormal operation.

Delayed Transition Transfer Switching

ASCO Delayed Transition Transfer Switches are designed to provide transfer of loads between power sources with a timed load disconnect position for an adjustable period of time. Applications include older style variable frequency drives, rectifier banks, and load management applications.

- Available 150 through 4000 amperes.
- Utilizes reliable, field proven solenoid operating mechanisms.
- Mechanical interlocks to prevent direct connection of both sources.
- Indicator light (16mm, industrial grade type LED) for load disconnect position.
- Adjustable time delay for load disconnect position.



Fig. 3: Four pole, Delayed-Transition Transfer Switch rated 2000 amperes.

ASCO® 7000 Series Power Switching Solutions

Non-Automatic Transfer Switching

ASCO Non-Automatic Transfer Switches are electrically operated units which are operated with manual control switches mounted locally or at remote locations.

- Sizes from 30 through 4000 amperes.
- Microprocessor based controller provides for addition of optional accessories.
- Controller prevents inadvertent operation under low voltage conditions.
- Low control circuit operating currents allow for long line runs between remotely mounted manual control switches and the transfer switch.
- Source acceptability lights inform operator if sources are available to accept load.
- Standard inphase monitor can be activated for transferring motor loads.



Fig. 4: Three pole Non-Automatic, electrically operated 400 ampere switch shown in Type 1 enclosure.

Withstand and Close-On Ratings for all 7000 Series Products⁽¹⁾⁽²⁾

Switch Rating (Amps)		UL 1008 Withstand and Close-On Ratings at 480 Volts AC				Short Time Withstand Ratings(4)	Short Time Duration (Cycles)	
Transfer Switches	Bypass Switches	Current - Limiting Fuse Rating	Max. Fuse Type		Specific Breaker Rating			"Any" Breaker (3) Rating
			amps	types				
30	-	100,000	60	J	10,000	10,000	N/A	-
70, 100, 150, 200	-	200,000	200	J	22,000	10,000	N/A	-
230	-	100,000	300	J	22,000	10,000	N/A	-
260, 400	150, 260, 400	200,000	600	J	42,000	35,000	N/A	-
600, 800, 1000, 1200	600, 800, 1000, 1200	200,000	1600	L	65,000	50,000	36,000 ⁵	18
1600, 2000 ⁶	1600, 2000	200,000	3000	L	100,000	100,000	65,000	30
3000	3000	200,000	4000	L	100,000	100,000	65,000	30
4000	4000	200,000	6000	L	100,000	100,000	65,000	30

Notes: 1) All values are available symmetrical RMS amperes and tested in accordance with the withstand and close-on requirements of UL 1008. See publication 1128 for more information on withstand and close-on ratings for ASCO transfer switches.

2) Application requirements may permit higher withstand ratings for certain size switches. Contact ASCO for guidance if available short circuit current exceeds the WCR ratings shown.

3) "Any" breaker ratings are based on 1.5 cycles for 30 - 230 amp & 3 cycles for 260 - 4000 amps. Applicable to breakers with instantaneous trip elements.

4) Short time ratings are provided for applications involving breakers that do not have instantaneous trips for system coordination.

5) Short time rating applicable to transfer switch design only.

6) Optional front connected service limited to 85,000 amps for specific and any breaker rating.

ASCO® 7000 Series Power Switching Solutions

Automatic Transfer Bypass-Isolation Switching

ASCO Automatic Transfer & Bypass-Isolation Switches are available in open transition, closed transition and delayed transition designs. The bypass and isolation features allow power transfer switches to be inspected, tested, and maintained without any interruption of power to the load.

- Available 150 to 4000 amperes.
- Allows bypass-isolation without load interruption.
- Bypass switch and transfer switch have identical electrical ratings.
- Heavy duty mechanical interlocks prevent undesirable operation.
- Bypass contacts carry current only during bypass mode.
- Transfer switch is drawout design for ease of maintenance.
- Bypass and isolation handles are permanently mounted. The bypass switch has dead front quick-make, quick-break operation for transferring of loads between live sources.
- Bypass switch is fully rated for use as a manual 3-position transfer switch.
- Bypass and isolation functions are simple, requiring a total of two operating handles.
- No toggle switches, push buttons, selector switches or levers are required for bypass-isolation operation.
- Mechanical indicators show bypass and transfer switch positions.



Fig. 5: Three Pole 7000 Series Automatic Bypass-Isolation Transfer Switch Rated 1000 Amps

Transfer Switch Drawout Features (600-3000 amperes)

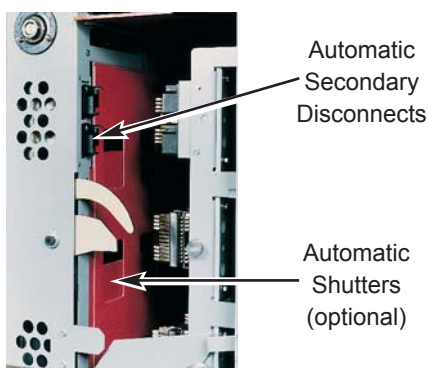

Fig. 6: Bypass-Isolation Transfer Switch secondary disconnects and optional automatic shutters.

- Automatic secondary disconnects remove all control power as switch is withdrawn.
- Drawout carriage provides for easy transfer switch maintenance and/or removal via commercially available breaker hoists.
- For optional transfer switch lifting yoke, specify accessory 82B.
- For optional automatic shutters which close when the transfer switch is withdrawn to provide bus isolation, specify accessory 82C.(1600-3000A only)

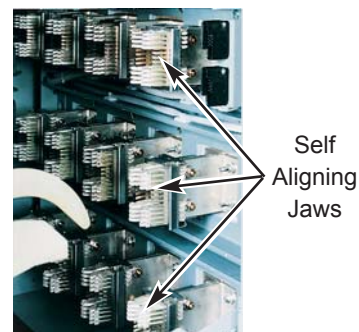

Fig. 7: Bypass-Isolation Transfer Switch self aligning power jaws.

ASCO® 7000 Series Power Switching Solutions

Bypass and Isolation Handles - Simple as 1, 2, 3

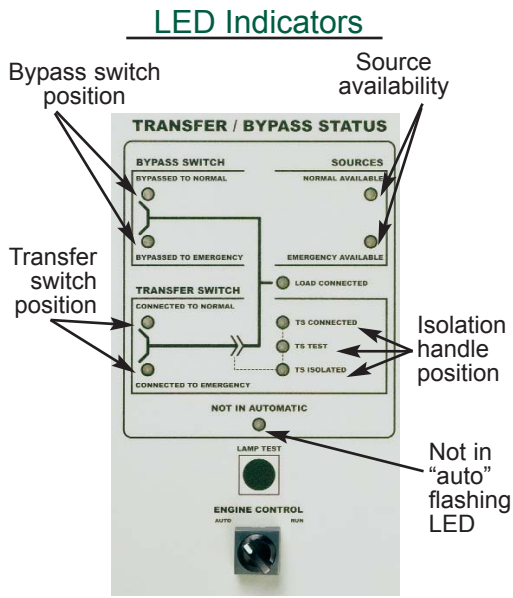
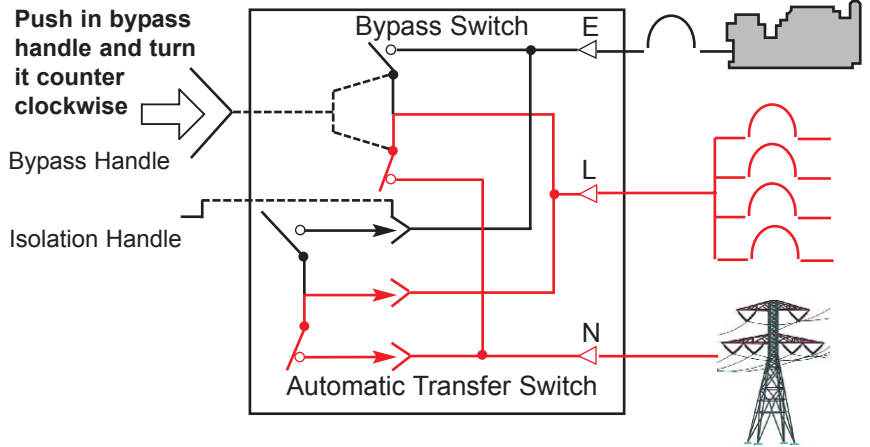

Fig. 8: Transfer Bypass Status Panel

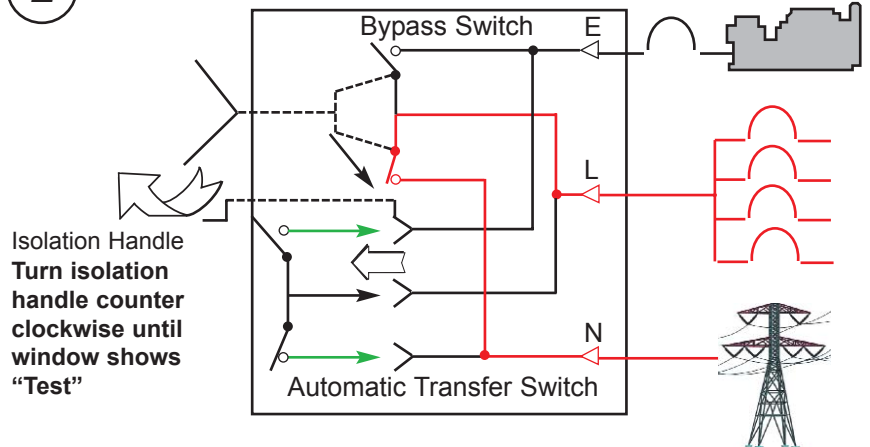

Fig. 9: Bypass-Isolation Switch user interface

1 Bypass to Normal



2 Test Position



3 Isolation Position

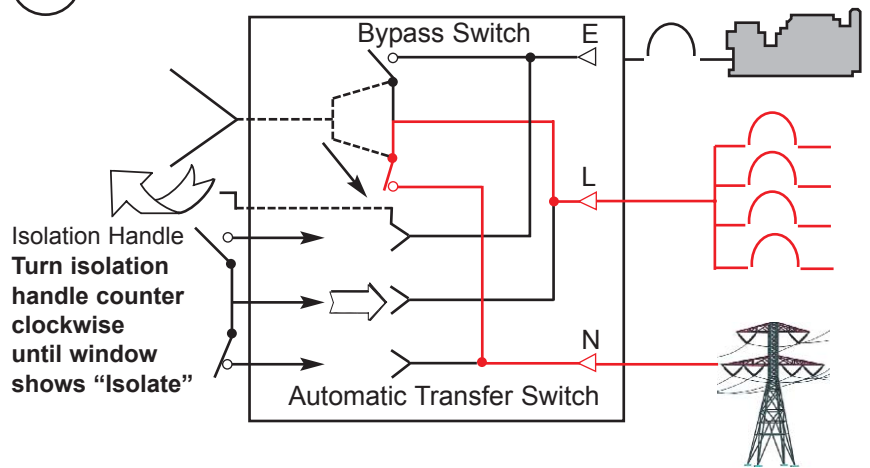

Key:

— Represents Current Flow

— In test position control panel remains energized to allow for electrical operation of a transfer switch.

ASCO[®] 7000 Series Service Entrance Power Transfer Switches

Optional Features

- Enclosures - Secure Double Door
 - ◆ UL Type 3R w/strip heater & thermostat
 - ◆ UL Type 4X
 - ◆ UL Type 12
- Connections
 - ◆ Crimp lugs
 - ◆ Bus Riser on Normal, Emergency or Load
- Protective Relays/Metering
 - ◆ ASCO 5200 Series Power Manager
- Surge Suppression
 - ◆ ASCO 451, 80KA Surge protector (see pg. 14)
- Communications
 - ◆ ASCO 72A Communication interface module
 - ◆ ASCO PowerQuest[®]
 - ◆ ASCO 5500 Series Thin Web Server for internet connection
- Additional Breaker(s)
 - ◆ Circuit Breaker on Emergency
 - ◆ Load Distribution Panel

Consult ASCO for additional features

Ordering Information

To order an ASCO 7000 Series Service Entrance Power Transfer Switch, complete the following catalog number.

7 A US + B + 3 + 400 + N + 5X + C

	Product	Neutral Code*	Phase Poles	Amperes	Voltage Code	Grp Code	Enclosure
A	Automatic	US Conventional 2-Position	--- No Neutral	2	70	C 208	C Type 1 enclosure
N	Non-Automatic	UB Open Transition Bypass	A Solid Neutral	3	100	D 220	M Type 3R secure double door
			B Switched Neutral		150	E 230	
			C Overlapping Neutral		200	F 240	
					225	H 380	
					250	J 400	
					400	K 415	
					600	L 440	
					800	M 460	
		1000	N 480				
		1200	P 550				
		1600	Q 575				
		2000	R 600				
		3000					
		4000					

*Note. Switches rated 150, 600-3000 amps available with 2, 3 or either conventional switched neutral (4 poles) or overlapping neutral (optional). For 4 pole applications on switches rates 260 to 400 amps and 4000 amps specify overlapping switched neutral (optional). Conventional switched neutral is provided on delayed transition transfer products when specified.

The Example Catalog Number above is 7AUSB3400N5XC (X is used to specify optional accessories).

Dimensions and Weights for non-bypass configurations only in type 1 enclosures. Consult ASCO for all other product configurations.

Switch Rating amps	Width inches (mm)	Height inches (mm)	Depth inches (mm)	Weight lbs (kg)
70 - 225	36.5 (927)	48.5 (1232)	13.25 (337)	408 (188)
250, 400	36.5 (927)	48.5 (1232)	13.25 (337)	408 (188)
600, 800	38 (965)	91 (2311)	28 (711)	820 (378)
1000-1200	38 (965)	91 (2311)	48 (1219)	1105 (510)
1600, 2000	38 (965)	91 (2311)	48 (1219)	2590 (1198)
3000	38 (965)	91 (2311)	72 (1829)	4590 (2148)
4000	46 (1168)	91 (2311)	72 (1829)	5640 (2609)

ASCO® 7000 Series Microprocessor Controller



Fig. 11: 7000 Series Microprocessor Controller.

The **7000 Series Microprocessor Based Controller** is used with all sizes of Power Transfer Switches from 30 through 4000 amperes. It represents the most advanced digital controller in the industry and includes, as standard, all of the voltage, frequency, control, timing and diagnostic functions required for most emergency and standby power applications.

Because of severe voltage transients frequently encountered with industrial distribution systems, the microprocessor logic board is separated and isolated from the power board as shown below. This improves electrical noise immunity performance and helps assure compliance with the rigorous transient suppression standards highlighted below.

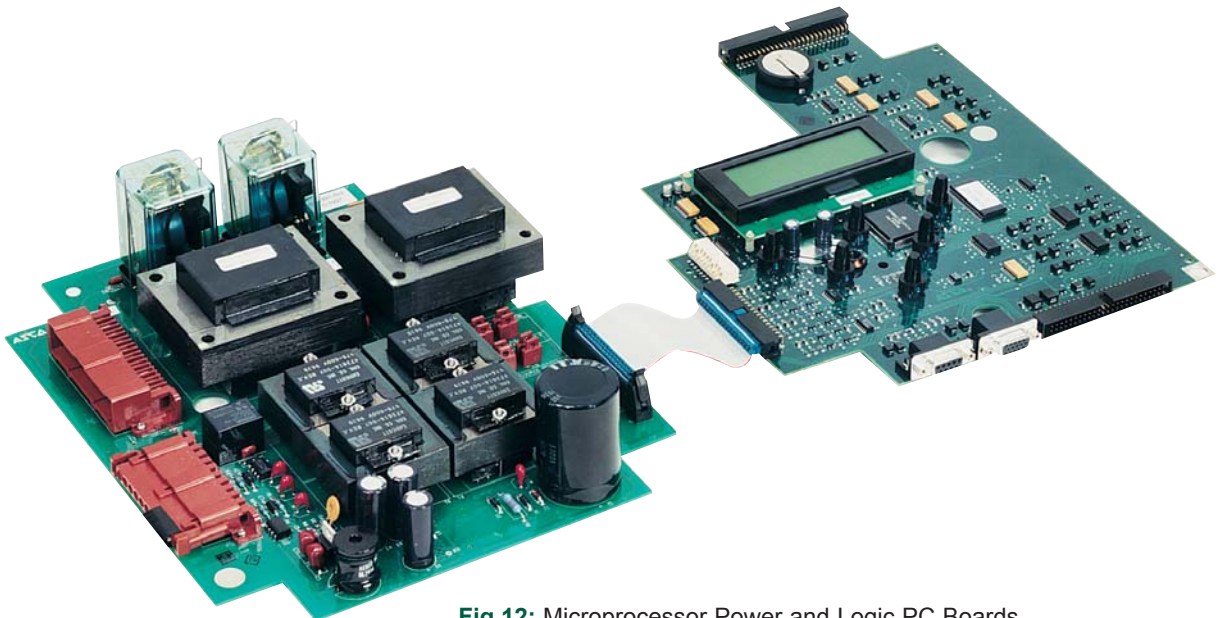

Fig.12: Microprocessor Power and Logic PC Boards.

7000 Series Microprocessor Based Controller	
Emission Standard - Group 1, Class A	EN 55011:1991
Generic Immunity Standard, from which:	EN 50082-2:1995
Electrostatic Discharge (ESD) Immunity	EN 61000-4-2:1995
Radiated Electromagnetic Field Immunity	ENV 50140:1993
Electrical Fast Transient (EFT) Immunity	EN 61000-4-4:1995
Surge Transient Immunity	EN 61000-4-5:1995
Conducted Radio-Frequency Field Immunity	EN 61000-4-6:1996
Voltage Dips, Interruptions and Variations Immunity	EN 61000-4-11:1994

ASCO[®] 7000 Series Microprocessor Controller

Features

- Digital microprocessor.
- Touch pad programming of features and settings without the need for meters, or variable power supplies.
- Sixteen (16) selectable operating voltages available in a single Controller.
- On-board diagnostics provide control panel and ATS status information to analyze system performance.
- Displays and counts down active timing functions.
- Selectable multi-language display (English, German, Portuguese, Spanish, or French. For others contact ASCO).
- Password protection to prevent unauthorized tampering of settings.
- Serial communications board (RS-485 protocol) for remote monitoring and control with ASCO PowerQuest[®] and SiteWeb[™] communications products. Specify optional accessory 72A.
- Load shed option for SYNCHROPOWER[®] bus optimization applications. Specify optional accessory 30B.

Voltage and Frequency Sensing

- 3-Phase under and over voltage settings on normal and emergency sources.
- Under and over frequency settings on normal and emergency.
- True RMS Voltage Sensing with +/- 1% accuracy; Frequency Sensing Accuracy is +/- 0.2%.
- Selectable settings: single or three phase voltage sensing on normal and emergency; 50 or 60Hz.
- Phase sequence sensing for phase sensitive loads.
- Voltage unbalance detection between phases.

Status and Control Features

- Output contact (N/O or N/C) for engine-start signals.
- Selection between “commit/no-commit” on transfer to emergency after engine start and normal restores before transfer.
- Advanced inphase algorithm which automatically measures the frequency difference between the two sources and initiates transfer at appropriate phase angles to minimize disturbances when transferring motor loads.
- Event log displays 99 logged events with the time and date of the event, event type and event reason.
- Output signals for remote indication of normal and emergency source acceptability
- Statistical ATS/System monitoring data screens which provide:
 - Total number of ATS transfers.
 - Number of ATS transfers caused by power source failure.
 - Total number of days ATS has been in operation.
 - Total number of hours that the normal and emergency sources have been available.

Time Delays

- Engine start time delay - delays engine starting signal to override momentary normal source outages - adjustable 0 to 6 seconds.
- Transfer to emergency time delay - adjustable 0 to 60 minutes.
- Emergency source stabilization time delay to ignore momentary transients during initial generator set loading - adjustable 0 to 6 seconds.
- Retransfer to normal time delay with two settings:
 - Power failure mode - 0 to 60 minutes.
 - Test mode - 0 to 60 minutes.
- Unloaded running time delay for engine cooldown - adjustable 0 to 60 minutes.
- Pre and post transfer signal time delay for selective load disconnect with a programmable bypass on source failures - adjustable 0 to 5 minutes. This signal can be used to drive a customer furnished relay, or for (2) sets of double throw contacts rated 3 amps at 480 volts AC, specify ASCO optional accessory 31Z.
- Fully programmable engine exerciser with seven independent routines to exercise the engine generator, with or without loads, on a daily, weekly, bi-weekly or monthly basis.
- Contains all alarm signals, logic and time delays for use with closed transition switches.
 - Insynch time delay - 0 to 3 seconds.
 - Failure to synchronize - 1 to 5 minutes.
 - Extended parallel - 0.1 to 1.0 seconds.
- Delayed transition load disconnect time delay - adjustable 0 to 5 minutes.

ASCO® 7000 Series User Controls and Indicators

Control Switches and Indicating Lights for Conventional 2-Position Switches

- Switch position indicating lights (16 mm, industrial grade LEDs).
- Source acceptability indicating lights with true indication of the acceptability of each source, as determined by the voltage, frequency, voltage unbalance, and phase sequence settings of the control panel (16mm, industrial grade LEDs).
- Three position (16mm, industrial grade type) selector switch:
- Automatic: Normal maintained position.
- Test: Momentary position to simulate normal source failure for system test function.
- Reset Delay Bypass: Momentary position to bypass transfer and re-transfer time delay.

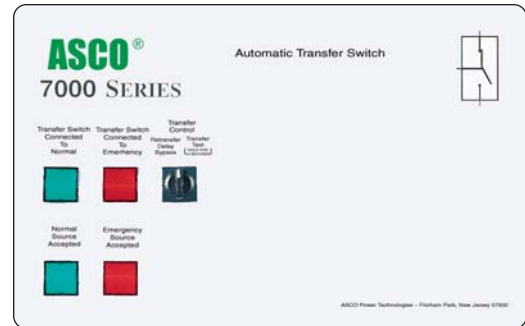

Fig. 13: 7000 Series User Controls and Indicators.

Control Switches and Indicating Lights for Closed Transition Switches

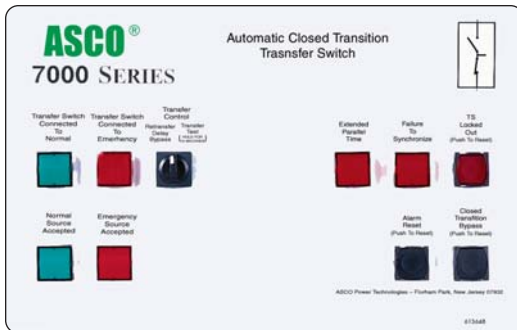

Fig. 14: 7000 Series User Controls and Indicators.

- **Extended Parallel Time** - Provides visual indication when the pre-set extended parallel time has been exceeded. The controls automatically open the emergency or normal main contacts. Separate contact also available to shunt trip external breaker.
- **Failure To Synchronize** - Visually displays a failure to synchronize alarm if the time delay settings is exceeded, during closed transition transfer operation.
- **TS Locked Out** - Prevents transfer in either direction if the extended parallel time is exceeded.
- **Alarm Reset** - Resets extended parallel and failure to synchronize alarms.
- **Closed Transition Bypass** - Pushbutton allows transfer between sources in an open transition mode.

7000 Series Transfer Control Center



Fig. 15: 7000 Series Transfer Control Center.

The 7000 Series microprocessor controller is a Transfer Control Center which allows the user to easily access detailed information on: system status; power source parameters; voltage, frequency and time delay settings; optional feature settings; historical event log; and system diagnostics. A four line, (20) character LCD has a backlit display which enables easy viewing under all conditions. The user can navigate through all screens using only six buttons, which also allows selection of: (18) different source parameter settings; (16) standard time delays; (12) standard feature settings; up to seven independent engine exercise routines; and even the language (English, German, Spanish, French, etc.) which appears on the display.

Since the Transfer Control Center must be visible and operable through the enclosure door, it has been qualified for use in industrial and outdoor applications. This includes installation in Type 3R (outdoor/rainproof), 4 (weatherproof) and 12 (indoor/industrial) enclosures.

ASCO® 7000 Series Transfer Control Center Screens

Status

<p>System Status</p> <p>Normal OK Load on Normal</p>	<p>Source Status</p> <p>Normal Source Vab=480V.....ABC Vbc=480V.....Vunbal=1% Vca=480V.....60.0Hz</p>
<p>Displays system status in clear, concise language. Message shown indicates normal source is acceptable and the load is connected to the normal source.</p>	<p>Displays voltage for each phase, frequency, phase rotation and voltage unbalance for both normal and emergency sources.</p>
<p>Time Delay Status</p> <p>Normal OK TD.Engine.Cooldown: 4min15s</p>	<p>Inphase Transfer Mode</p> <p>Emerg OK Waiting for In-Sync -45o 0.02Hz</p>
<p>Active time delay status displays time remaining until next control event.</p>	<p>Displays the relative phase angle between sources and frequency differential to indicate the controller is awaiting an inphase condition.</p>

Settings

<p>Voltage and Frequency Settings</p> <p>Normal Voltage Dropout.....85%.408V Pickup.....90%.432V O.V. Trip.....110%.528V</p>	<p>Time Delay Settings</p> <p>TD N>E Xfer Signal Bypass if N Fail: No Pre Xfer: 0 min 20S Post Xfer: 0 min 20S</p>
<p>Provides voltage and frequency setting values for normal and emergency sources. Voltage pick-up, dropout and trip settings are set in percentage of nominal voltage and are also displayed in rms voltage values.</p>	<p>Provides direct reading display for setting time delays.</p>
<p>Engine Exerciser</p> <p>P1.....Engine.Exerciser Enable:....Yes...WLoad:....Yes Start:19h30. ALL MON Run.Time:.....2h15min</p>	<p>Feature Settings</p> <p>Shed Load Direction: From E Inphase: No TD/0.25</p>
<p>Seven independent programs, load/no load selection, flexible run times and daily, weekly, bi-weekly and monthly exercise routines.</p>	<p>Standard features can be activated with the keypad. As an example, when enabled, the “shed load” option causes the transfer switch to transfer the load off of the specified source. If desired, the load shed transfer can be made inphase.</p>

Data Logging

<p>ATS Statistics</p> <p>ATS Statistics ATS Total Xfers: 46 SRC Fail Tot Xfers: 20 Days Energized: 36.5</p>	<p>Historical Event Log</p> <p>16.AUG02/95.....13h10:17 Eng.Start.....NormFail. 15.AUG02/95.....13h10:25 Xfer.N>E.....</p>
<p>Instant availability of statistical information on total number of ATS transfers, number of transfers caused by power failures and total days controller has been energized, plus more.</p>	<p>Displays detailed information for last 99 events, including time of occurrence, length of event, date and reason for event.</p>

ASCO® 7000 Series Optional Accessories

Time Delays

- 2C** The standard feature one time delay is adjustable from 0 to six seconds to delay engine starting. If necessary, extended time delay on engine starting is available. Adjustable from 0 to 60 min in one second steps. Factory set at five minutes.
- 1G** Similar to accessory 2C except using 24 volt DC external input signal.

Manual Controls for Automatic Transfer Switches

- 6C** Reset switch for manual retransfer to normal with automatic retransfer in the event of emergency source failure.
- 6D** Selector switch for automatic/manual retransfer to normal. Automatic bypass if emergency fails.

Engine Generator Controls and Accessories

- 12** Three position engine control selector switch.
Positions: 1- Stop 2- Automatic 3- Engine Test

Note: Switches with accessory 12 must be labelled as a non-automatic transfer switch according to UL 1008.

Engine controls containing "engine stop" positions should be located at the engine generator. (Consult ASCO for application assistance.)

Indicators

- 14A/14B** Additional auxiliary contact sets to indicate switch position. Two sets are standard. Specify total number of sets if more are required.
- 18B** Two-pole, double-throw contacts operate when emergency source voltage is present at transfer switch terminals.
- 18G** Two-pole, double-throw contacts operate when normal source voltage is present at transfer switch terminals.
- 99** "Push-to-Test" feature on all pilot light indicators.

Customer Control Circuits

- 30A** Load-shedding circuit initiated by opening of a customer-supplied contact.
- 30B** Load-shedding circuit initiated by removal of customer-supplied control voltage. (Specify voltage).
- 31Z** Selective load disconnect control contacts (two provided) which operate with time delay prior to and/or after load transfer and retransfer.
- 43R** Terminal block for all customer control connections on 30-150 amp only (standard on all other sizes).

Note: An externally operable quick-make, quick-break (QM QB), manual handle is available on some 7000 Series product configurations. (Consult ASCO for guidance.)

Neutral Conductor Options

- Solid neutral, with fully-rated terminals. (AL-CU) UL Listed.
- Conventional neutral switching pole.
- Overlapping neutral transfer contacts. Allows for proper ground-fault sensing and avoids generator voltage transients during transfer.

Note: Specify neutral option in catalog number, see page 21 for instructions.

Extension Harness

- 37B** Six foot (6') extension harness to increase distance between transfer switch and control panel on open-type units.

Analog Load Metering Options

- 23B** Three phase ammeter with selector switch (with current transformers and shorting blocks).
- 24B** Three phase voltmeter with selector switch.

Note: Refer to ASCO 7000 Series Data Monitor on page 15 which provides voltage, frequency and power monitoring.

Serial Communications

- 72A** Serial communication module for remote communications to ASCO PowerQuest® products.

Surge Protection

ASCO Pulsar 450 rated 40KA

- 73AC1** Normal source protection. (3Ø, 4wire WYE)
- 73AC2** Emergency source protection. (3Ø, 4wire WYE)
- 73AC3** Load side protection. (3Ø, 4wire WYE)

Note: Other distribution voltages available (Contact ASCO).

Special Applications

- 111A** Generator - to - Generator for Standby Applications
- 111B** Generator - to - Generator for Prime Power Applications

Bypass Isolation Switch Options

- 14A1** Auy contact to close in "Bypass to Normal" position.
- 14B1** Auxiliary contact to close in "Bypass to Emergency" position.
- 14T** Auxiliary contact to close when transfer switch is in "Automatic" position.
- 14U** Auxiliary contact to close when transfer switch is in "Isolate" position.
- 14V** Auxiliary; contact to close when transfer switch is in "Test" position.

ASCO® 7000 Series Optional Accessories

ASCO® Power Manager

The ASCO Power Manager is a microprocessor based metering device that provides real-time measurements of single and three phase power systems. The Power Manager uses digital signal processing technology to measure voltage and current per phase; real, reactive and apparent power, and bi-directional energy. All measurements can be viewed locally with a backlit liquid crystal display and/or displayed remotely with ASCO PowerQuest® or SiteWeb™ products.

Direct voltage input for systems up to 600 Volts AC can be monitored without the use of external potential transformers (PTs). Measures three phase currents and a fourth current input is available for measuring current in the neutral conductor. The Power Manager includes one discrete input for transfer switch position, eight general purpose discrete inputs, and four relay outputs for controlling or monitoring external devices.

Power Metering

- Voltage:
 - Line - Line: VAB, VBC, VCA, VAVERAGE
 - Line - Neutral: VAN, VBN, VCN, VAVERAGE
- Frequency: 45.0 to 66.0 Hertz
- Current: IA, IB, IC, IAVERAGE
- Unbalance %: Voltage, Amps
- Real Power: KWA, KWB, KWC, KWNET
- Reactive Power: KVARA, KVARB, KVARC, KVARNET
- Apparent Power: KVAA, KVAB, KVAC, KVANET
- Real Energy: KWHIMPORT, KWHEXPORT, KWHNET
- Reactive Energy: KVARHIMPORT, KVARHEXPORT, KVARHNET
- Power Factor: PFA, PFB, PFC, PFNET

Data Access

- Eight digital inputs, four relay outputs.
- Input/Output 15-character, user definable screen display for identification of input/output signals.



Fig. 16: ASCO Power Manager.

Configurable Designations

- Local - A four line 20 character LCD backlit display.
- Remote - With optional Acc. 72A communication module and Power Manager monitoring systems.
- Provides a user programmable setpoint based on watt demand and can be used to control one of the four relay outputs. Used for peak shaving applications

Integrated ATS Features

- When configured on load of ATS:
 - Displays ATS position.
 - Displays power data as a function of ATS position (normal/emergency).
 - Accumulates energy data separately for normal and emergency sources.

Optional Configurations and Connection Arrangements

<u>Connected To:</u>	<u>With Display</u>	<u>Without Display</u>
Load	Acc. 85L	Acc. 75L
Normal	Acc. 85N	Acc. 75N
Emergency	Acc. 85M	Acc. 75M
Load (BPS only)	Acc. 85R*	Acc. 75R*

Add suffix "A" to above designations if neutral conductor monitoring is required.

Note: Accessory 75 and 85 includes component mounting, CTs, shorting blocks and all necessary interwiring.

* Bypass & isolation switch contacts wired to discrete Power Manager inputs.

Note: The ASCO Power Manager is also available as a separate unit for monitoring electrical parameters anywhere in the power distribution system.

ASCO® 7000 Series Power Monitoring & Control

ASCO Connectivity Solutions

ASCO PowerQuest® and SiteWeb™ communications products allow for the monitoring and control of power transfer switches in your Emergency or Standby Power Distribution System. Local Area networks and Remote networks are supported with either single or multiple points of access, and web-enabled communications allow access to your power system from anywhere around the world.

Features

- Monitors and Controls Power Transfer Switches and Engine Generators
- Monitors Normal and Emergency Voltages and Frequency
- Indicates Transfer Switch Position and Source Availability
- Provides Transfer and Retransfer of Loads for System Testing
- View Normal and Emergency Voltage and Frequency Settings
- View Transfer Switch Time-Delay Settings
- Provides Transfer Switch Rating and Identification
- Automatic Paging Notifies Personnel, by E-mail or Pager, of Selected System Alarms
- View Current, Power and Power Factor with ASCO Power Managers Connected to the System
- Adjust and Set Transfer Switch Controller Parameters
- Activate Transfer Switch Control Functions, Such as Inphase Transfer, Selective Load Disconnect Time Displays and Engine Exerciser Programming
- View Transfer Switch Event Log
- Provides Transfer Switch Test Schedule

PowerQuest® Typical Network Connection

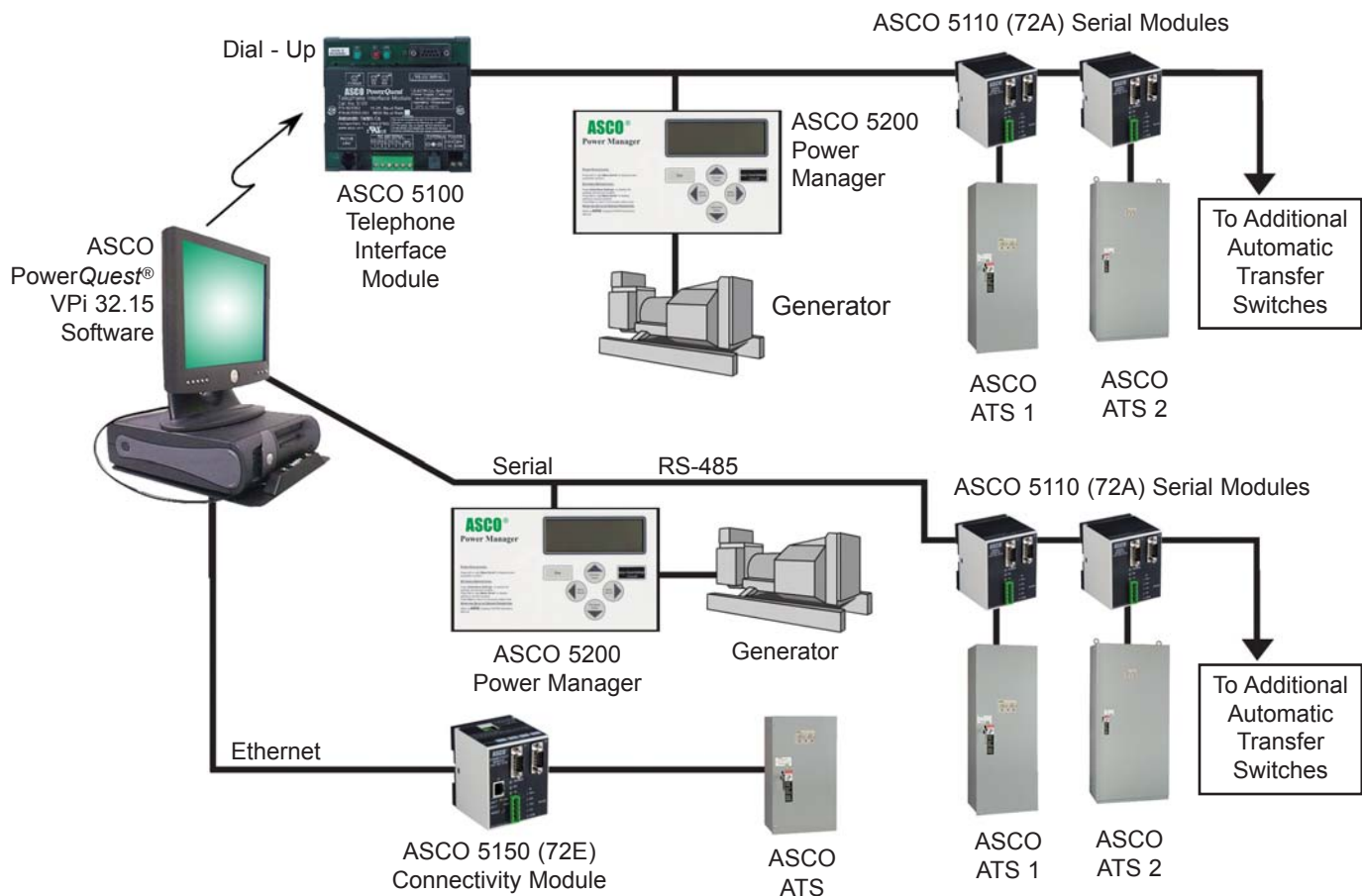

ASCO® 7000 Series Power Monitoring & Control

PowerQuest® is a PC based software package. When combined with the ASCO Communication Interface Module (Acc 72A), the ASCO 5120 Telephone Interface Module and ASCO 5200 Series Power Manager, as shown above, it provides the most economical communication system for monitoring and control of power transfer switches and engine generators.

The local RS-485 network allows communications with up to 32 power transfer switches and four engine generators. An analog phone connection and ASCO telephone interface module allow for direct dial up, monitoring and control of remote locations. The ASCO Power Manager not only allows you to view current power and power factor readings, but also has a programmable KW set point to initiate transfer of loads to a standby source for peak shaving operations.



Fig. 17: Serial Module 72A

5110 Serial Module

Serial Module (5110) is used to allow local or remote communications with ASCO PowerQuest® or SiteWeb™ communication products.

The module is used to connect the 7000 Series Transfer Switches, and ASCO Power Managers to the serial network via an RS-485 interface. The module has two port connectors used for ATS & Standalone Power Manager connectivity. The serial connection is accomplished from a 5-pin terminal header/socket block. The module is designed to communicate with up to 32 devices.



Fig. 18: Connectivity Module 72E

5150 Connectivity Module

Connectivity Module (5150) is used to bring several different serial devices that communicate at different baud rates and with different protocols to a common Ethernet media.

The module is used to connect 7000 Series Transfer Switches, and ASCO Remote Annunciators to the standard Ethernet TCP/IP network with standard 10base T(RJ-45) connector. The module has been built in customized JAVA™ applets (program applications for an internet browser) for each monitored device that loads automatically to a standard Web Browser.

The module is designed to communicate with up to 8 clients simultaneously with Web applications (web pages), PowerQuest®, or third party Modbus® devices over an Ethernet connection.



Fig. 19: Telephone Interface Module

5100 Telephone Interface Module

(for use with PowerQuest®)

The ASCO Telephone Interface Module (TIM) allows users to dial directly into their ASCO communications network for monitoring and/or control. The TIM connects to the ASCO communication network via RS-485 and the phone port connects directly into an analog phone jack. Also, the TIM has an RS-232 connector which allows the TIM to be used as the dialing modem.

Supplied with 120 VAC to 18 VDC (nominal) UL approved, class 2 power supply.

Summary Screen

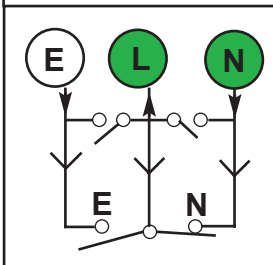
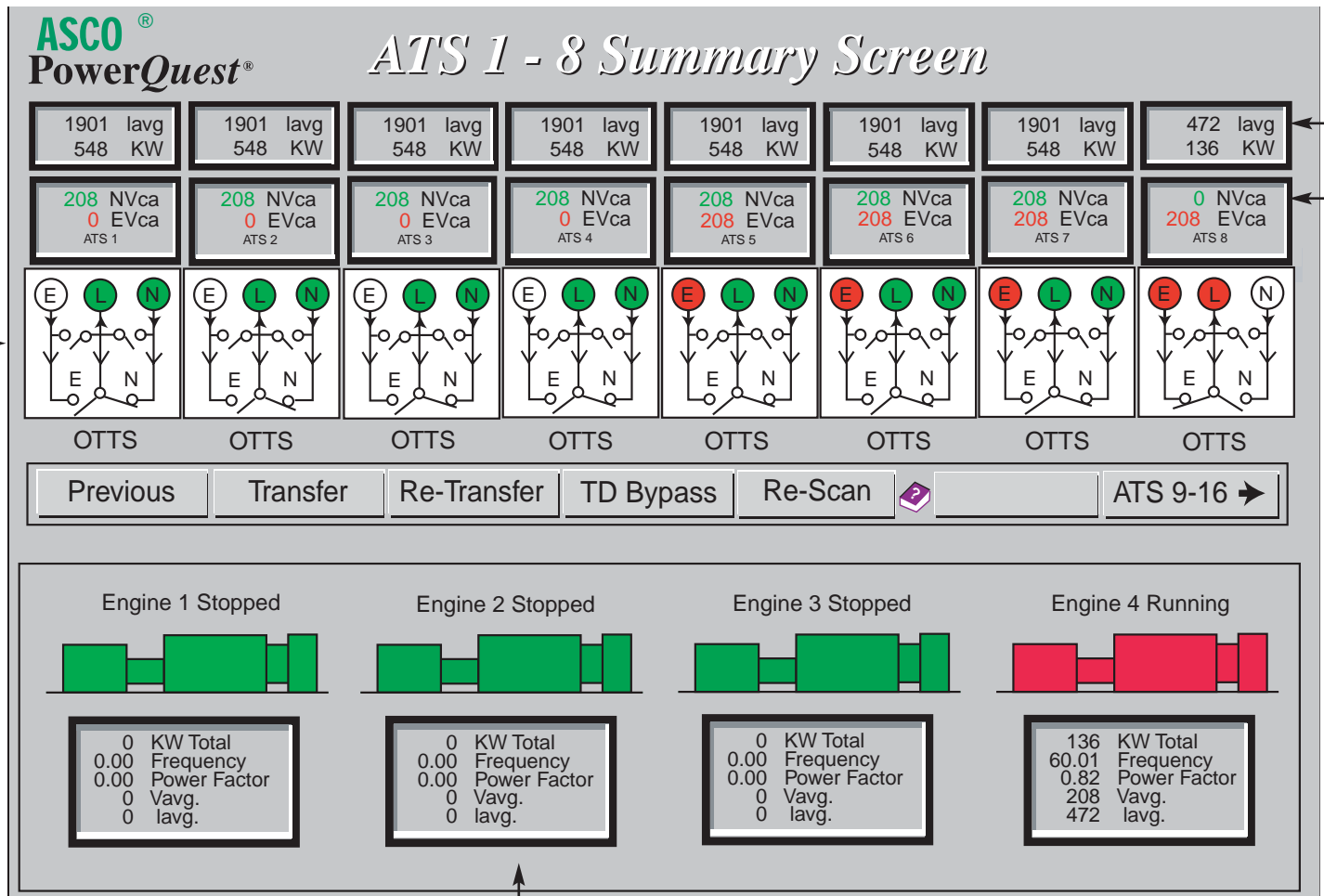

Convenient One-Line Diagram

- Colored icons highlighted to show source availability and which source is connected to load.
- Contacts move on icon to indicate main contact position of transfer and bypass switch.
(Automatic transfer and automatic transfer and bypass isolation switches must be provided with optional accessory 14 auxiliary contacts shown on page 14.)
- Bypass switch contacts appear on icon when configured by user input data.

ASCO® Power Manager / Data Monitor Screen
PowerQuest®

ADDRESS 8

Voltage		Current		Normal Energy	
Voltage AB	207	Current A	475	KWH imp	890763
Voltage BC	209	Current B	469	KWH exp	0
Voltage CA	208	Current C	472	KWH net	890763
Voltage AN	119	Unbal %	40	KVARH lag	85
Voltage BN	120	Power		KVARH lead	78
Voltage CN	121	KWatt	136	KVARH net	163
Unbal % L-L	1	KVAR	0	Emergency Energy	
Frequency	59.97	KVA	136	KWH imp	21
Power Factor	1			KWH lead	7
				KWH net	25
				KVARH lag	2
				KVARH lead	1
				KVARH net	3
				Reset Normal	Reset Emergency

Digital Input	Status	Digital Output	Toggle	Status
Status Input 1	<input type="checkbox"/>	Start Engine	Relay 1	on
Bypass to Normal	<input type="checkbox"/>	Output 2	Relay 2	off
Bypass to Emergency	<input type="checkbox"/>	Output 3	Relay 3	off
ATS Test	<input type="checkbox"/>	Output 4	Relay 4	off
ATS Isolated	<input type="checkbox"/>			
Normal Breaker Trip	<input type="checkbox"/>			
Status Input 7	<input type="checkbox"/>			
Status Input 8	<input type="checkbox"/>			

Device	Rating
CT Ratio	1000
PT Ratio	120

USER NONE

Power Manager Detail Screen

- Voltage: phase to phase; phase to neutral and voltage unbalance.
- 3 phase currents and neutral (optional).
- Frequency.
- Kilowatt hours - normal and emergency.
- Status and control of four relay outputs.
- Status of eight digital inputs.
- Device ratings: CT and PT ratio.

Transfer Switch Detail Screen

- ATS rating and identification data is displayed.
- Allows remote testing and time delay bypass.
- Voltage, frequency, phase sequence, voltage unbalance and time delay settings can be checked.
- Viewing of engine exercise schedules.
- Displays phase to phase voltage on normal and emergency.
- Provides complete system status message from 7000 series microprocessor controller.
- View event log on the last 99 events for each ATS.
- Arrange test schedules for transfer switches.
- Provides for monitoring of local site or remote sites.

ASCO® PowerQuest® Transfer Switch
ATS Details Screen

Description: ATS 8 Location: Switch 1 Ver. ADRTST-E12

Transfer Switch Data

Parameter	Value
ATS Locked Out	No
Nom Voltage	208
Current Rating	1200
Nom Freq	50
# Phases	1
Normal Vab	202
Normal Vbc	205
Normal Vca	205
Normal Freq	59
Emerg Vab	0
Emerg Vbc	0
Emerg Vca	0
Emerg Freq	0

PRESENT STATE: Load On Normal, Normal OK

Normal Voltage Frequency Settings

Voltage or Freq	% Nom	Value
Voltage P.U.	95	197.6
Voltage D.O.	70	197.6
Voltage Trip	0	0
Freq P.U.	95	47.5
Freq D.O.	90	45
Freq Trip	0	0
Voit Unbal P.U.	10	20.8
Voit Unbal D.O.	20	41.6

Time Delay Settings [min]:[sec]

Setting	Value
Engine Start-Norm Fail	00:03
Norm to Emerg	00:10
Emerg to Norm-Src Fail	30:00
Emerg to Norm-Test Xfer	02:00
Emerg to Norm-Emerg Fail	00:00
Engine Cool Down	03:00

Event Logging (Max. 99 Entries)

Event Log	Event Cause
Emerg Became Not Vail	Emergency Failure

Date: 06/12/01
Time: 16:05:42

USER None

ASCO® PowerQuest® Engine-Generator Screen
ENGINE 4

Voltage		Current		Power		Energy	
Voltage AB	207	Current A	475	KW Total	136	KWH imp	890784
Voltage BC	209	Current B	469	KWH net	43441	KWH exp	0
Voltage CA	208	Current C	472	Frequency	60	KVARH lag	78
Voltage AN	119	Unbal %	40	Power Factor	60	KVARH net	163
Voltage BN	120	Reset					
Voltage CN	121						
Unbal % L-L	1						

Digital Input	Alarm Enabled	Status	Digital Output	Toggle	Status
Engine Oil Temp	No	<input type="checkbox"/>	Start Engine	Relay 1	on
Low Fuel	No	<input type="checkbox"/>	Output 2	Relay 2	off
Low Oil Pressure	Yes	<input type="checkbox"/>	Output 3	Relay 3	off
Bypass Closed	No	<input type="checkbox"/>	Output 4	Relay 4	off
Bypass on Test	No	<input type="checkbox"/>			
Normal Brkr Temp	No	<input type="checkbox"/>			
Status Input 7	No	<input type="checkbox"/>			
Status Input 8	No	<input type="checkbox"/>			

USER NONE

Engine-Generator Details

- Voltage: Phase to phase; Phase to neutral
- Current for each phase.
- Kilowatts and kilowatt hours total.
- Frequency and power factor.
- Status and control of four digital outputs which can be customized by the user.
- Status of eight digital inputs.
- "Alarm Enabled" selection. These alarms flash the "engine-generator" icon on the summary screen.
- Digital inputs for engine malfunctions are derived from engine mounted sensors (supplied by others).

ASCO® SiteWeb™

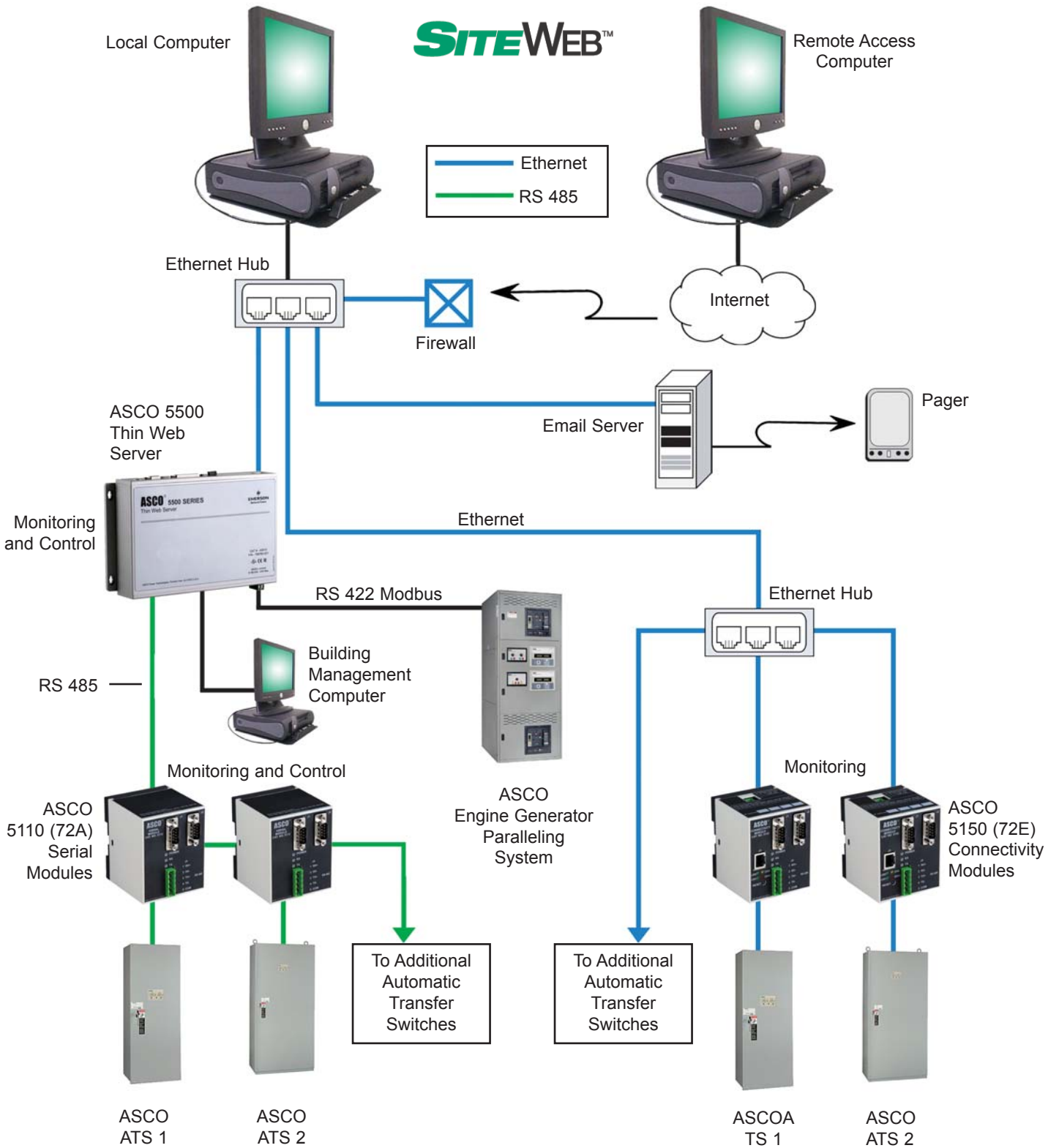

ASCO® SiteWeb™

SiteWeb™ is a client-server application requiring no software to be installed on the client computer. When combined with the ASCO Communication Interface Modules (Acc 72A / Acc 72E), the ASCO 5500 Series Thin Web Server and the ASCO 5200 Series Power Manager, as shown above, it provides the most comprehensive Intranet and Internet communication system for the monitoring and control of power transfer switches and engine generators located in your emergency or standby power distribution system.

The SiteWeb™ communication system allows multiple client access, from local or remote locations, and provides for the monitoring of up to 64 power transfer switches and eight engine generators. In addition, automatic paging is provided for all alarm signals.



Fig. 20: Thin Web Server

5500 Series Thin Web Server (for use with **SITEWEB™** products)

The ASCO Thin Web Server allows you to monitor and control transfer switches and engine generators anytime over the Internet or an Intranet from anywhere in the world. It also transmits a page message that an alarm has occurred with one or more of the transfer switches. Plus, this is possible from your home computer or anywhere that has Internet service, using the ASCO Thin Web Server single-board computer with its embedded SiteWeb™ HTML web pages.

Communications Products for Series 7000 Transfer Switches

Description	Acc. Option	Catalog No.
Serial Module	72A	5110
Connectivity Module	72E	5150
Telephone Interface Module for Remote Monitoring*	—	5120
Power Manager with Display*	—	5200D
Thin Web Server*	—	5510E
Thin Web Server with Modem*	—	5510M
PowerQuest VPi Software Package*	—	VPi 32.15

*Note: These products are available as separate items only. They can be ordered by catalog numbers shown in above chart.

PowerQuest® / SITEWEB™ / Connectivity Modules

ASCO Connectivity Solution Guide Feature	PowerQuest Vpi 32.15	Thin Web Server with SiteWeb	Series 5150 Connectivity Module
Quantity of Monitored / Controlled Power Transfer Switches per LAN	32	64	1024+
Number of Monitored / Controlled Gensets	4	8	1024+
Control & Monitoring Capability	Yes	Yes	No
Embedded Web Pages	No	Yes	Yes
Ethernet Network Compatible	Yes	Yes	Yes
Monitor Multiple Protocols & Baud Rates (ASCO I, ASCO II, Modbus)	No	No	Yes
Monitor Multiple Sites	Dial-Up	Internet	Intranet
Multiple Client Access	No	Up to 8	Up to 8
Client Software Required	Yes	Internet Explorer	Internet Explorer
Monitors Dissimilar ASCO Controllers on Common LAN	No	No	Yes
Communicates with ASCO Remote Annunciators	No	No	Yes
Email / Paging Alarms	No	Yes	No
Historical Trending Option Alarms	No	Yes	No

ASCO® 7000 Series Ordering Information

To order an ASCO 7000 Series Power Transfer Switch, complete the following catalog number:

7 **A** **TS** + **A** + **3** + **400** + **N** + **5X** + **C**

		Product		Neutral Code*		Phase Poles	Amperes	Voltage Code		Grp Code	Enclosure	
A	Automatic	TS	Conventional 2-Position	---	No Neutral	2 3	30 70	A B	115 120	5 5X- optional accessories	---	No enclosure
			TB	Open Transition Bypass	A	Solid Neutral	100 150	C D	208 220		C E	Type 1 enclosure Type 2 enclosure
N	Non-Automatic	CTS		Closed Transition	B	Switched Neutral	200*	E	230		F	Type 3R enclosure
			230*				H	380	G		Type 4 enclosure	
M	Manually Operated	DTS	Delayed Transition	C	Overlapping Neutral	260	J	400	H		Type 4X enclosure (stainless steel)	
						400	K	415	L		Type 7 enclosure	
M	Manually Operated	DTB	Delayed Transition Bypass	C	Overlapping Neutral	600	L	440	K		Type 7 enclosure	
						800	M	460	L		Type 12 enclosure	
M	Manually Operated	DTB	Delayed Transition Bypass	C	Overlapping Neutral	1000	N	480	M		Type 3R secure double door	
						1200	P	550	N		Type 4 secure double door	
M	Manually Operated	DTB	Delayed Transition Bypass	C	Overlapping Neutral	1600	Q	575	P	Type 4X secure double door		
						2000	R	600	Q	Type 12 secure double door		
M	Manually Operated	DTB	Delayed Transition Bypass	C	Overlapping Neutral	3000						
						4000						

*Note: Switches rated 30-230, 600-3000 amps available with 2, 3 or either conventional switched neutral (4 poles) or overlapping neutral (optional).
For 4 pole applications on switches rated 260 to 400 amps and 4000 amps specify overlapping switched neutral (optional).
Conventional switch neutral is provided on delayed transition transfer products when specified.
200 and 230 amp switch limited to 480 volts maximum.

**The Example Catalog Number above is 7ATSA3400N5XC
(X is used to specify optional accessories).**

Transfer Switch Configurations

7A TS, 7N TS, 7A DTS, 7A CTS, 7N DTS, 7N CTS

Sizes of UL-Listed Solderless Screw-Type Terminals for External Power Connections

Switch Rating amps	Max # of Conductors per Terminal	Range of AL-CU Conductor Sizes
30 -230 ³	One	#14 to 4/0 AWG
260-400	One	#4 AWG to 600 MCM
	Two	#1/0 AWG to 250 MCM
600	Two	#1/0 AWG to 600 MCM
800-1200 ¹	Four	#1/0 AWG to 600 MCM
1600-2000	Six	#1/0 AWG to 600 MCM
3000	Twelve	#1/0 AWG to 600 MCM
4000 ²	Suitable for Bus Bar Connection or Lugs Can Be Field Modified	

Notes: 1. Unit is designed for top cable entry of emergency and load and bottom entry of normal. Optionally, the switch may be supplied with reverse source and/or bottom entry load, when specified.

2. All main terminals are rear connected. The 4000 amp switch is arranged for bus bar connection. Contact ASCO if provisions for cable connection are required.

Transfer/Bypass Configurations

7A TB, 7N TB, 7A DTB, 7A CTB, 7N DTB, 7N CTB

Sizes of UL-Listed Solderless Screw-Type Terminal for Power Connections

Switch Rating amps	Max # of Conductors per Terminal	Range of AL-CU Conductor Sizes
150,260,400	One	# 4 AWG to 600 MCM
	Two	# 1/0 AWG to 250 MCM
600 ⁴	Two	# 2 AWG to 600 MCM
800,1000,1200 ⁴	Four	# 1/0 AWG to 600 MCM
1600-2000 ⁴	Six	# 1/0 AWG to 600 MCM
3000 ⁴	Ten	# 2 AWG to 600 MCM
4000 ⁴	Twelve	# 2 AWG to 600 MCM

3. 200 and 230 amp rating for copper conductors only.

4. All main terminals are rear connected. A front connected version is available in 600 and 800 amp ratings only with top cable entry only. See pages 24 and 25 for dimensional data.

ASCO[®] 7000 Series Designed to Fit Anywhere

2-Position Transfer Switching 7A TS, 7N TS (Non-Bypass)

Switch Rating amps	Poles	Width inches (mm)	Height inches (mm)	Depth inches (mm)
Enclosed UL Type 1²				
30, 70, 100, 150, 200, 230	2, 3 or 3 with neutral A/B/C	18 (457)	48 (1219)	13 (330)
260, 400	2, 3 or 3 with neutral A/C	22 (559)	48 (1219)	13 (330)
600, 800, 1000	2, 3 or 3 with neutral A/B/C	34 (864)	72 (1829)	20 (508)
1200	2, 3 or 3 with neutral A/B/C	38 (965)	87 (2210)	23 (584)
1600, 2000 ¹	2, 3 or 3 with neutral A/B/C	38 (965)	91 (2311)	48 (1219)
3000 ¹	2, 3 or 3 with neutral A/B/C	38 (965)	91 (2311)	60 (1524)
4000 ¹	2, 3 or 3 with neutral A/C	46 (1168)	91 (2311)	72 (1829)
Open Configuration				
30, 70, 100, 150, 200, 230	2, 3 or 3 with neutral B/C	10-1/4 (260)	10-1/4 (260)	5-1/2 (140)
260, 400	2 or 3	12 (305)	18-1/2 (470)	6-7/8 (175)
260, 400	2 or 3 with neutral C	14-1/2 (368)	18-1/2 (470)	6-7/8 (175)
600, 800, 1000, 1200	2, 3 or 3 with neutral B/C	27 (686)	31 (787)	12-7/8 (327)
1600, 2000	2, 3 or 3 with neutral B/C	33-1/4 (845)	28 (711)	26-1/4 (667)
3000	2, 3 or 3 with neutral B/C	33-1/4 (845)	28 (711)	30-3/4 (781)
4000	2, 3 or 3 with neutral C	41 (1041)	52 (1321)	25-1/2 (648)

Notes: 1. Enclosures for 1600 - 4000 amp are free-standing with removable top, sides, and back.

2. Consult ASCO for dimensions on enclosures other than UL type 1.

Shipping Weights

2-Position Transfer Switching 7A TS, 7N TS

Switch Rating amps	Poles	Enclosed lb (kg)	Open lb (kg)*
30, 70, 100	2	67 (31)	15 (7)
30, 70, 100	3	70 (32)	18 (8)
30, 70, 100	3 with B/C	73 (33)	21 (10)
150, 200, 230 (Open)	2	69 (32)	17 (8)
150, 200, 230 (Open)	3	72 (33)	20 (9)
150, 200, 230 (Open)	3 with B/C	75 (34)	23 (11)
230, 260, 400	2	117 (53)	37 (17)
230, 260, 400	3	125 (57)	45 (21)
230, 260, 400	3 with C	133 (61)	53 (24)
600, 800, 1000	2	400 (182)	150 (68)
600, 800, 1000	3	420 (192)	170 (78)
600, 800, 1000	3 with B/C	446 (203)	196 (90)
1200	2	685 (312)	150 (68)
1200	3	705 (321)	170 (78)
1200	3 with B/C	731 (333)	196 (90)
1600, 2000	2	1110 (503)	370 (167)
1600, 2000	3	1160 (525)	420 (190)
1600, 2000	3 with B/C	1210 (548)	470 (213)
3000	2	1365 (620)	405 (184)
3000	3	1430 (649)	470 (213)
3000	3 with B/C	1495 (679)	535 (243)
4000	2	2208 (1002)	975 (443)
4000	3	2433 (1104)	1200 (545)
4000	3 with C	2533 (1149)	1300 (590)

Notes: *Open weights include transfer switch and control panel.

1200-4000 amp enclosures require ventilation openings, refer to drawings for details.

Export shipments may require a wooden box, contact ASCO for weights and dimensions.

ASCO® 7000 Series Designed to Fit Anywhere

Closed Transition and Delayed Transition Transfer Switching 7A DTS, 7A CTS, 7N DTS, 7N CTS

Switch Rating amps	Poles	Width inches (mm)	Height inches (mm)	Depth inches (mm)
Enclosed UL Type 1³				
150, 260, 400 ¹	2, 3 or 3 with neutral A/C	24 (610)	63 (1600)	17-1/2 (445)
600, 800, 1000	2, 3 or 3 with neutral A/B	34 (864)	72 (1829)	20 (508)
1200	2, 3 or 3 with neutral A/B	38 (965)	87 (2210)	23 (584)
1600, 2000 ²	2, 3 or 3 with neutral A/B	38 (965)	91 (2311)	48 (1219)
3000 ²	2, 3 or 3 with neutral A/B	38 (965)	91 (2311)	60 (1524)
4000 ²	2, 3 or 3 with neutral A/C	46 (1168)	91 (2311)	72 (1829)
Open Configuration				
150, 260, 400	2, 3 or 3 with neutral C	14-3/4 (375)	30 (762)	5-7/8 (149)
600, 800, 1000, 1200	2, 3 or 3 with neutral B	27 (686)	31 (787)	12-7/8 (327)
1600, 2000	2, 3 or 3 with neutral B	33-1/4 (845)	28 (711)	26-1/4 (667)
3000	2, 3 or 3 with neutral B	33-1/4 (845)	28 (711)	30-3/4 (781)
4000	2, 3 or 3 with neutral C	41 (1041)	52 (1321)	29-1/2 (749)

- Notes: 1. For 400 amp, 7A DTS and 7N DTS with neutral code B; dimensions are 34 (864) X 72 (1829) x 20 (508).
 2. Enclosures for 1600 - 4000 amp are free-standing with removable top, sides, and back.
 3. Consult ASCO for dimensions on enclosures other than UL type 1

Shipping Weights

Closed Transition and Delayed Transition Transfer Switching 7A DTS, 7A CTS, 7N DTS, 7N CTS

Switch Rating amps	Poles	Enclosed lb (kg)	Open* lb (kg)
150, 260, 400	2	137 (62)	45 (21)
150, 260, 400	3	145 (66)	53 (24)
150, 260, 400	3 with C	153 (69)	63 (28)
600, 800, 1000	2	420 (192)	175 (80)
600, 800, 1000	3	450 (205)	205 (94)
600, 800, 1000	3 with B	480 (219)	235 (108)
1200	2	710 (324)	175 (80)
1200	3	740 (337)	205 (94)
1200	3 with B	770 (351)	235 (108)
1600, 2000	2	1300 (590)	505 (229)
1600, 2000	3	1350 (612)	555 (252)
1600, 2000	3 with B	1400 (635)	605 (274)
3000	2	1555 (706)	540 (245)
3000	3	1620 (735)	660 (300)
3000	3 with B	1685 (765)	725 (329)
4000	2	2360 (1071)	1127 (511)
4000	3	2580 (1171)	1347 (611)
4000	3 with C	2680 (1217)	1447 (657)

- Notes: *Open weights include transfer switch and control panel.
 1200-4000 amp enclosures require ventilation openings, refer to drawings for details.
 Export shipments may require a wooden box, contact ASCO for weights and dimensions.

ASCO[®] 7000 Series Designed to Fit Anywhere

Automatic Transfer Bypass-Isolation Switching with Transfer Switch Engaged 7A TB, 7N TB

Switch Rating amps	Poles	Width inches (mm)	Height inches (mm)	Depth inches (mm)
Enclosed UL Type 1				
150, 260, 400 ¹	2, 3 or 3 with neutral A/C	28-1/2 (724)	62-1/2 (1588)	19 (483)
600, 800 (Front Connected) ^{2, 5}	2, 3 or 3 with neutral A/B/C	38 (965)	91 (2311)	32 (813)
600, 800, 1000, 1200 ^{2, 3}	2, 3 or 3 with neutral A/B/C	38 (965)	91 (2311)	48 (1219)
1600, 2000 ^{2, 3}	2, 3 or 3 with neutral A/B/C	38 (965)	91 (2311)	60 (1524)
3000 ^{2, 3}	3 or 3 with neutral A/B/C	38 (965)	91 (2311)	72 (1829)
4000 ⁴	3 or 3 with neutral A/C	96-1/2 (2451)	91 (2311)	72 (1829)
Open Configuration				
150, 260, 400 ¹	2 or 3	14-3/4 (375)	37-1/8 (946)	22-1/4 (565)
150, 260, 400 ¹	2 or 3 with neutral C	19-3/4 (500)	61-1/2 (1553)	22-1/4 (565)
600, 800, 1000, 1200 ^{2, 3}	2, 3 or 3 with neutral B/C	38 (965)	72 (1829)	38 (965)
1600, 2000 ³ , 3000 ^{2, 3}	2, 3 or 3 with neutral B/C	38 (965)	72 (1829)	38 (965)

- Notes: 1. Handles extend 3-1/2 inches (89mm).
 2. Handles extend 6-1/4 inches (159mm).
 3. Recommended clearance to enclosure: 3 feet (914mm) from rear, 4 feet (1219mm) from front (25 inches required for transfer switch drawout). Side or rear access required.
 4. For 4000 amp size, ATS and bypass sections can be reversed, contact ASCO. Recommended clearance to enclosure: 3 feet (914mm) from rear, 5 feet (1524mm) from front (3 feet required for transfer switch rollout).
 5. Specify optional accessory 40HY for 600 amp front - connected arrangement and 40 JY for 800 amp. All service and load cables limited to top entry only.

Shipping Weights

Automatic Transfer Bypass-Isolation Switching with Transfer Switch Engaged 7A TB, 7N TB

Switch Rating amps	Poles	Enclosed lb (kg)	Open* lb (kg)
150, 260, 400	2	340 (154)	135 (61)
150, 260, 400	3	350 (158)	145 (66)
150, 260, 400	3 with C	360 (163)	155 (70)
600, 800, 1000, 1200	2	1510 (685)	920 (417)
600, 800, 1000, 1200	3	1580 (717)	990 (449)
600, 800, 1000, 1200	3 with B/C	1650 (748)	1060 (481)
1600, 2000	2	2180 (989)	1300 (589)
1600, 2000	3	2360 (1070)	1550 (702)
1600, 2000	3 with B/C	2540 (1152)	1800 (815)
3000	3	2730 (1240)	1690 (768)
3000	3 with B/C	3360 (1525)	1980 (899)
4000	3	6300 (2858)	—
4000	3 with C	6900 (3130)	—

- Notes: *Open weights include transfer switch, bypass-isolation switch and control panel.
 1600-4000 amp enclosures require ventilation openings, refer to drawings for details.
 Export shipments may require a wooden box, contact ASCO for weights and dimensions.

ASCO® 7000 Series Designed to Fit Anywhere

Automatic Transfer Bypass-Isolation in Closed Transition and Delayed Transition Switching. 7A DTB⁶, 7A CTB, 7N DTB⁶, 7N CTB

Switch Rating amps	Poles	Width inches (mm)	Height inches (mm)	Depth inches (mm)
Enclosed UL Type 1				
150, 260, 400 ^{1,5}	2, 3 or 3 with neutral A/C	28-1/2 (724)	74 (1880)	19 (483)
600, 800 (Front Connected) ^{2,7}	2, 3 or 3 with neutral A/B	38 (965)	91 (2311)	32 (813)
600, 800, 1000, 1200 ^{2,3}	2, 3 or 3 with neutral A/B	38 (965)	91 (2311)	48 (1219)
1600, 2000 ^{2,3}	2, 3 or 3 with neutral A/B	38 (965)	91 (2311)	60 (1524)
3000 ^{2,3}	3 or 3 with neutral A/B	38 (965)	91 (2311)	72 (1829)
4000 ⁴	3 or 3 with neutral A/C	96-1/2 (2451)	91 (2311)	72 (1829)
Open Configuration				
150, 260, 400 ^{1,5}	2 or 3	14-3/4 (375)	61-1/2 (1553)	22-1/4 (565)
150, 260, 400 ^{1,5}	2 or 3 with neutral C	19-3/4 (500)	61-1/2 (1553)	22-1/4 (565)
600, 800, 1000, 1200 ^{2,3}	2, 3 or 3 with neutral B	38 (965)	72 (1829)	38 (965)
1600, 2000 ³ , 3000 ^{2,3}	2, 3 or 3 with neutral B	38 (965)	72 (1829)	38 (965)

- Notes:
1. Handles extend 3-1/2 inches (89mm).
 2. Handles extend 6-1/4 inches (159mm).
 3. Recommended clearance to enclosure: 3 feet (914mm) from rear, 4 feet (1219mm) from front (25 inches required for transfer switch drawout). Side or rear access required.
 4. For 4000 amp size, ATS and bypass sections can be reversed, contact ASCO. Recommended clearance to enclosure: 3 feet (914mm) from rear, 5 feet (1524mm) from front (3 feet required for transfer switch rollout).
 5. Dimensions for 400 amp, 7A DTB and 7N DTB with neutral code B are 38(965)W x 91(2311)H x 48(1219)H.
 6. Conventional switched neutral is provided on 7A DTB and 7N DTB switching arrangements when specified (optional Code B).
 7. Specify optional accessory 40HY for 600 amp front - connected arrangement and 40 JY for 800 amps. All service and load cables limited to top entry only.

Shipping Weights

Automatic Transfer Bypass-Isolation in Closed Transition and Delayed Transition Switching. 7A DTB, 7A CTB, 7N DTB, 7N CTB

Switch Rating amps	Poles	Enclosed lb (kg)	Open* lb (kg)
150, 260, 400	2	340 (154)	145 (66)
150, 260, 400	3	350 (158)	155 (70)
150, 260, 400	3 with C	360 (163)	165 (75)
600, 800, 1000, 1200	2	1560 (708)	970 (440)
600, 800, 1000, 1200	3	1630 (739)	1040 (472)
600, 800, 1000, 1200	3 with B	1700(771)	1110(503)
1600, 2000	2	2315 (10550)	1435 (651)
1600, 2000	3	2495 (1132)	1685 (764)
1600, 2000	3 with B	2675 (1213)	1935 (878)
3000	3	2730 (1240)	1690 (768)
3000	3 with B	3360 (1525)	1980 (899)
4000	3	6300 (2858)	–
4000	3 with C	6900 (3130)	–

- Notes:
- *Open weights include transfer switch, bypass-isolation switch and control panel.
 - 1600-4000 amp enclosures require ventilation openings, refer to drawings for details.
 - Export shipments may require a wooden box, contact ASCO for weights and dimensions.

ASCO® Start-Up Commissioning, Service & Scheduled Maintenance



ASCO Services, Inc., provides a wide range of technical services to users of automatic transfer switches in emergency and standby power systems. These services include comprehensive scheduled maintenance programs, modifications, upgrades and emergency repairs. Systems serviced range in complexity from a single automatic transfer switch to multiple transfer switches and engine generators.

ASCO Services is a wholly owned subsidiary and the exclusive OEM service arm of ASCO Power Technologies, the world's

largest manufacturer of power transfer switching and control equipment. Serving the needs of ASCO's customers is a major focus; however, ASCO Services is also routinely called upon to perform regular maintenance and emergency repairs on equipment manufactured by others.

ASCO Services offers comprehensive maintenance agreements that detail the preventive care needed to keep emergency power systems ready to respond. A service agreement is an effective way to budget in advance and avoid unexpected expenditures. A 35-

point checklist is utilized to assure critical systems and components are kept in top operating condition. These preventive programs can be customized for national accounts. This customization permits central corporate control of costs and scheduling. Periodic reports provide detailed information as to activity, maintenance performed and corrective action.

ASCO Services deploys more than 75 service personnel strategically located throughout the nation to provide 24-hour response in emergency situations. Each region is manned by ex-

perienced personnel who receive ongoing support and training in the newest equipment concepts, design and controls. Because equipment can be utilized for a long number of years, field representatives also receive education on older designs. This knowledge can be invaluable in addressing total system concerns, evaluating problems and providing solutions on site. Service vans are equipped with parts and advanced testing equipment that facilitate these on-the-spot repairs. ASCO® Services 1-800-800-ASCO.

ASCO Power
Technologies®

We Keep Your Power On®

A S C O P O W E R T E C H N O L O G I E S
F L O R H A M P A R K , N E W J E R S E Y 0 7 9 3 2
U S A

8 0 0 8 0 0 A S C O
W W W . A S C O . C O M

ASIA

AUSTRALIA

BRAZIL

CANADA

GERMANY

JAPAN

MEXICO

SOUTH AFRICA

SOUTH AMERICA

UNITED ARAB EMIRATES

UNITED KINGDOM

UNITED STATES

